



Omar Castañón Freyre, ABB-Perú, Julio 2014

SOLUCIONES EN SUBESTACIONES DE ALTA TENSIÓN UTILIZANDO CELDAS COMPACTAS HIBRIDAS

Substations

- Es el conjunto de elementos que sirven para controlar el flujo de energía y garantizar su seguridad por medio de sistemas de protección.
- Esta asociado a la necesidad de transportar la energía desde su centro de generación hasta su consumo, optimizando el nivel de tensión desde un punto de vista técnico-económico.
- Las subestaciones estan conformadas por interruptores de potencia, seccionadores, transformadores de medida, pararrayos, barra de conexión, transformadores de potencia en muchos casos, complementados con sistemas de control y protección como reles, comunicaciones y servicios auxiliares.
- Las Subestaciones podemos clasificarlas según el aislamiento como AIS (air insulated switchgear), GIS (gas insulated switchgear).
- Veamos algunos ejemplos de estos:

Power Systems division

AIS: SUBESTACION EN AIRE

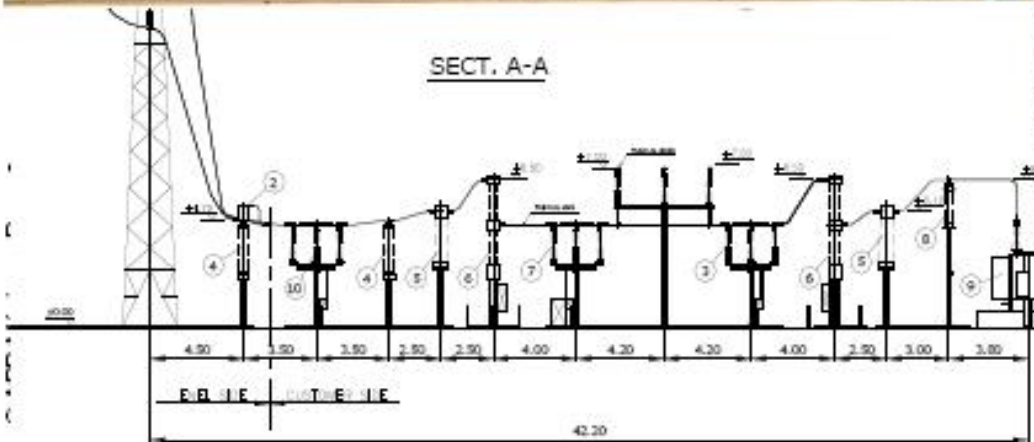

Power Systems division

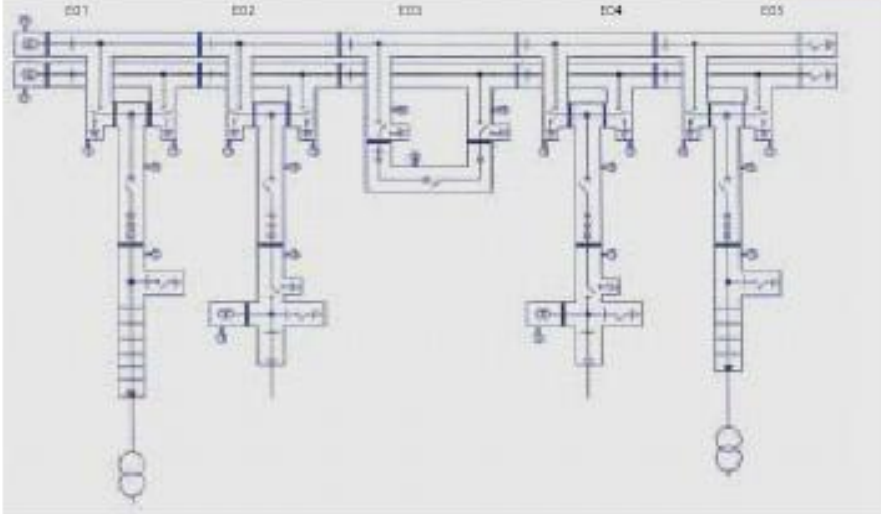

GIS: SUBESTACION EN GAS



Power Systems division

Celda Compacta Híbrida

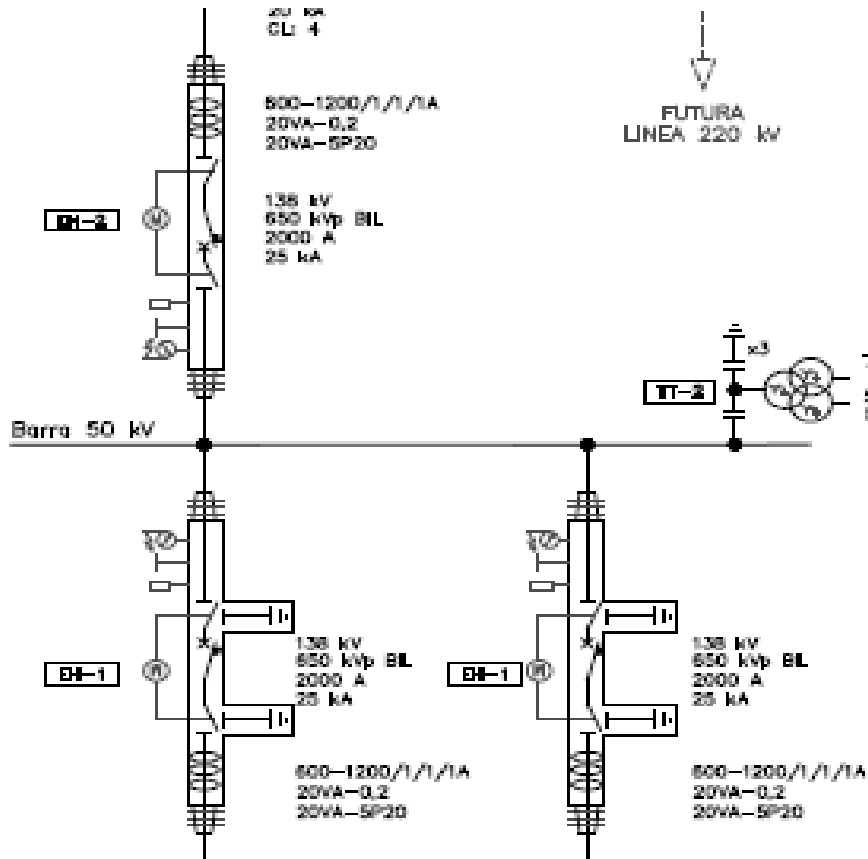

PASS (Plug And Switch Systems)

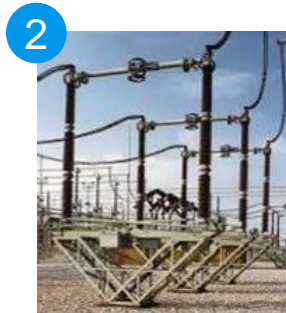
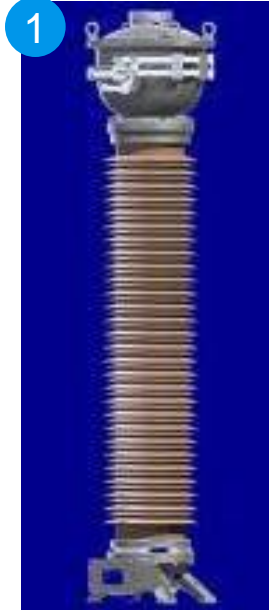

- Transformador de Corriente
- Seccionador de barra + Seccionador de puesta a tierra
- Transformador de Tensión
- Interruptor de potencia.

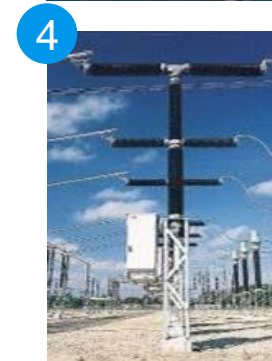

PASS (Plug And Switch Systems)

TODAS LAS FUNCIONES CONTENIDAS EN UN MODULO

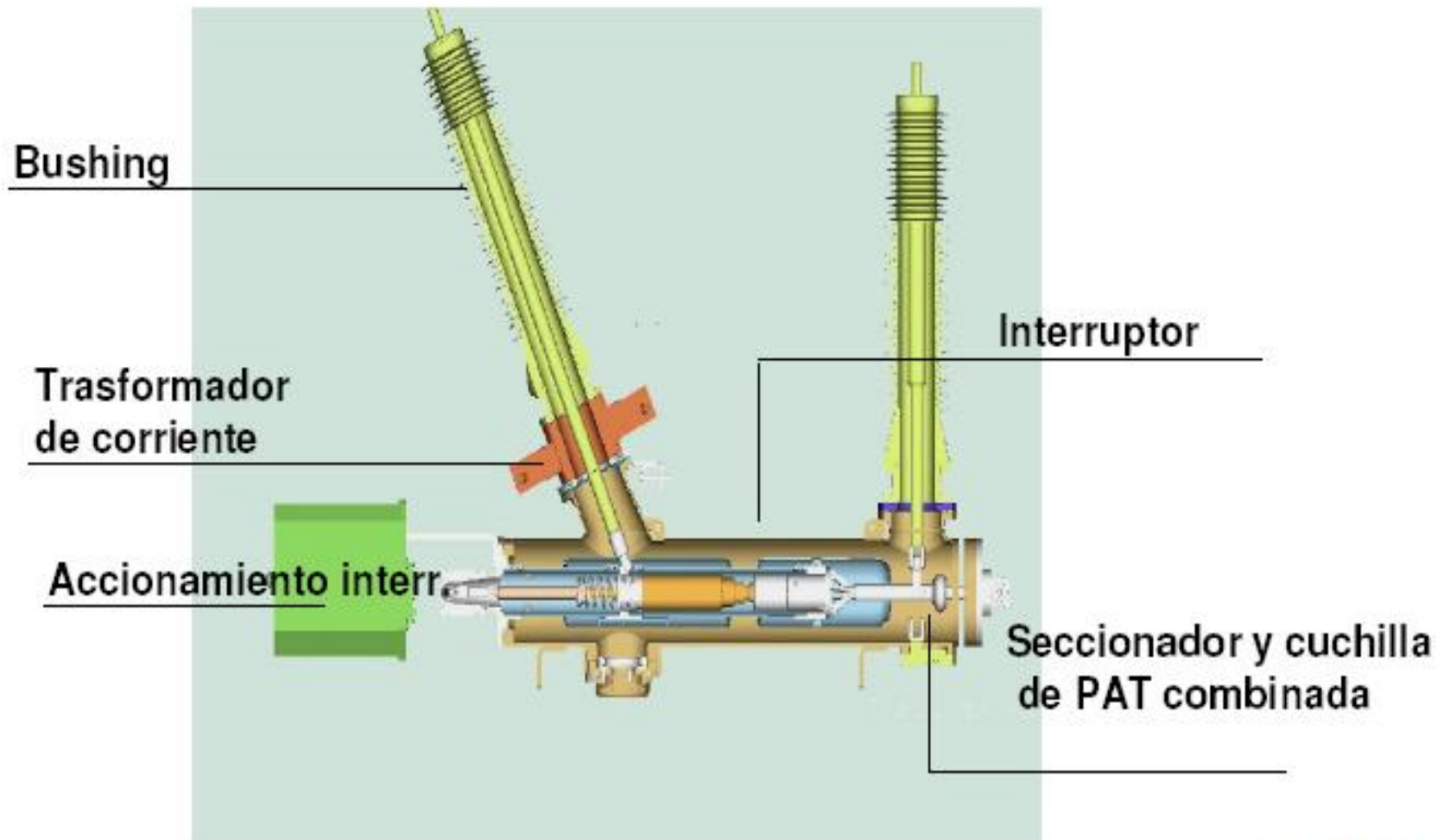

PASS (Plug And Switch Systems)

Conventional AIS

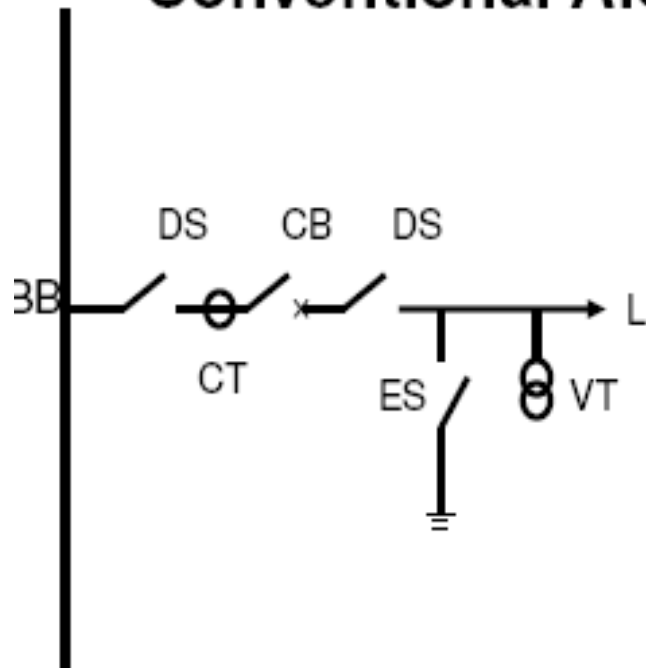

PASS M0 SBB

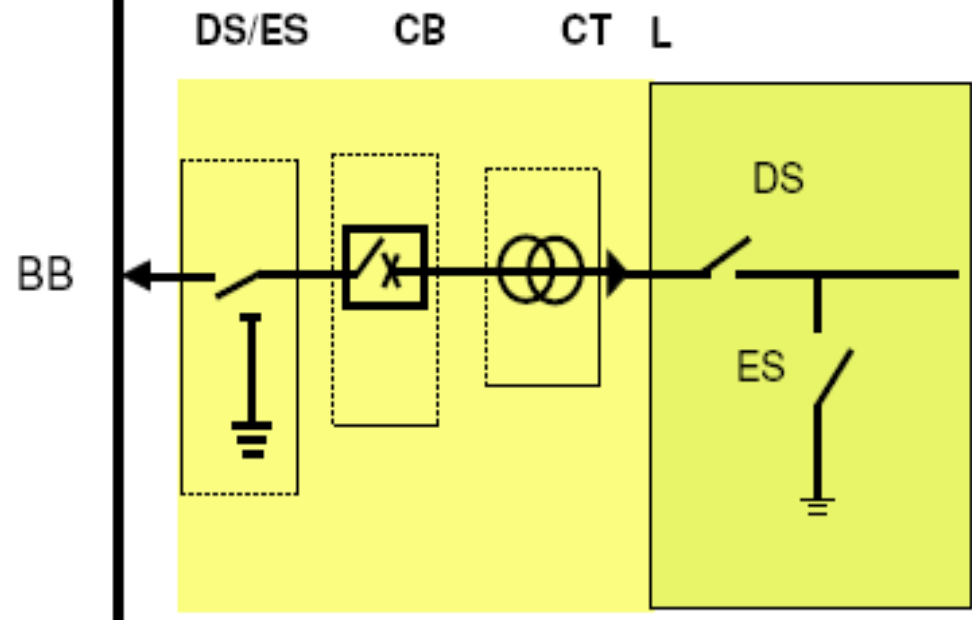

Nomenclatura:

Interruptor de Potencia,- CB

Transformador de Corriente.- CT

Transformador de Potencial.- VT

Desconectador de Línea,- DS

Cuchilla de puesta a tierra.- ES

PASS (Plug And Switch Systems)

INTERRUPTOR TIPO AIS

CAMARA DEL INTERRUPTOR MODELO LTB

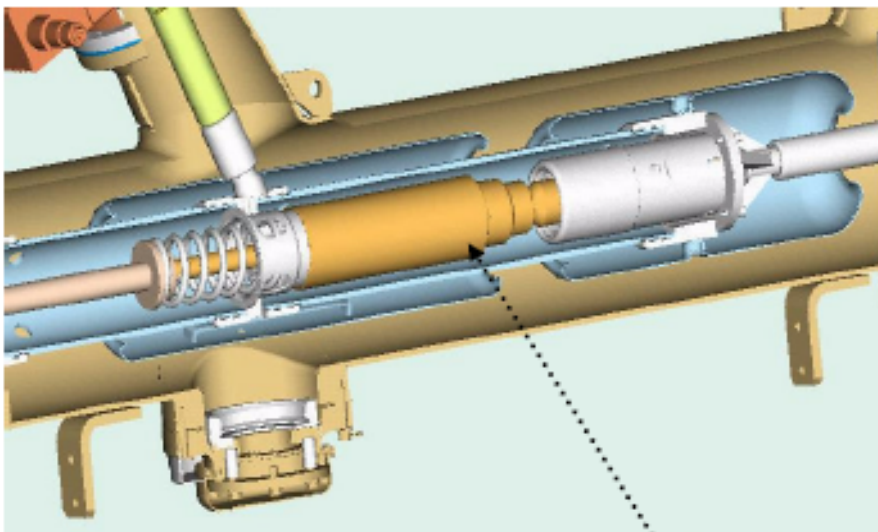

CIRCUIT BREAKER

Frequency	Hz	50	60
Type	LTB-D		
Operating mechanism (spring type, three pole operated)	BLK 222		
Operating mechanism (spring type, single pole operated)	BLK 82		
Rated operating sequence acc. to IEC	O - 0.3 s - CO - 1 min - CO		
Stored switching sequence	O - CO		
Rated current	A	2500	
Rated short-time withstand current	kA	40	
Rated making current	kA	100	104
Rated short circuit duration	s	1	

**Probado con 10,000
operaciones dentro de la
envolvente.**

PASS (Plug And Switch Systems)

DESCONECTADOR TIPO GIS

SOLUCION SENCILLA Y CONFIABLE QUE OTORGA LAS FUNCIONES DE SECCIONADOR Y PUESTA A TIERRA

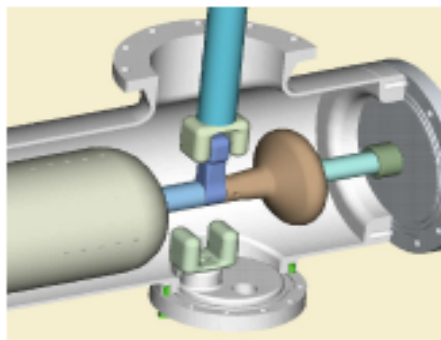

DS - closed



ES - open

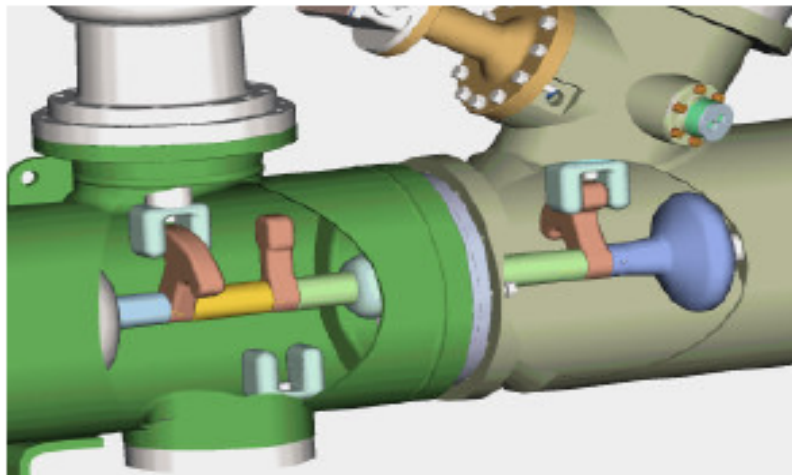

COMBINED DISCONNECTOR & EARTHING SWITCH					
Type	SBL				
Operating mechanism (three pole operated)	BES-7				
Rated voltage	kV	72.5	123	145	170
Rated power frequency withstand voltage					
<i>common value</i>	kV	140	230	275	325
<i>across the isolating distance</i>	kV	160	265	315	375
Rated lightning impulse withstand voltage (1 sec)					
<i>common value</i>	kV	325	550	650	750
<i>across the isolating distance</i>	kV	375	630	750	860
Rated current	A	2500			
Rated short time withstand current	kA	40			
Rated peak current	kA	108			
Rated short circuit duration	s	1			
Motor operating time (disconnecter)	s	< 4			

PASS (Plug And Switch Systems)

MIRILLA DESCONECTOR

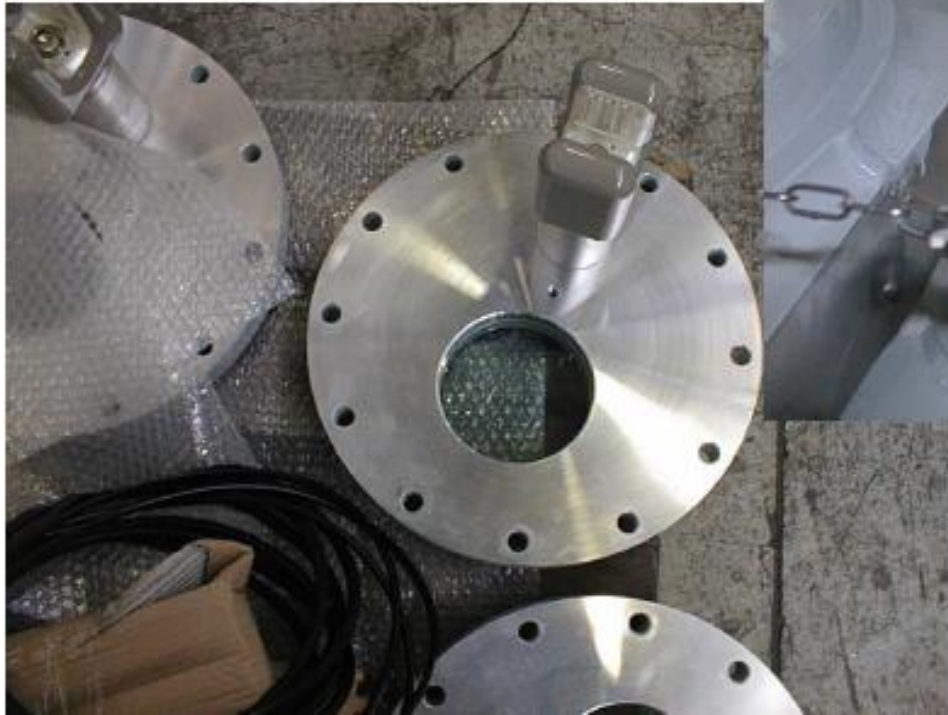

PASS (Plug And Switch Systems)

MIRILLA DESCONECTOR

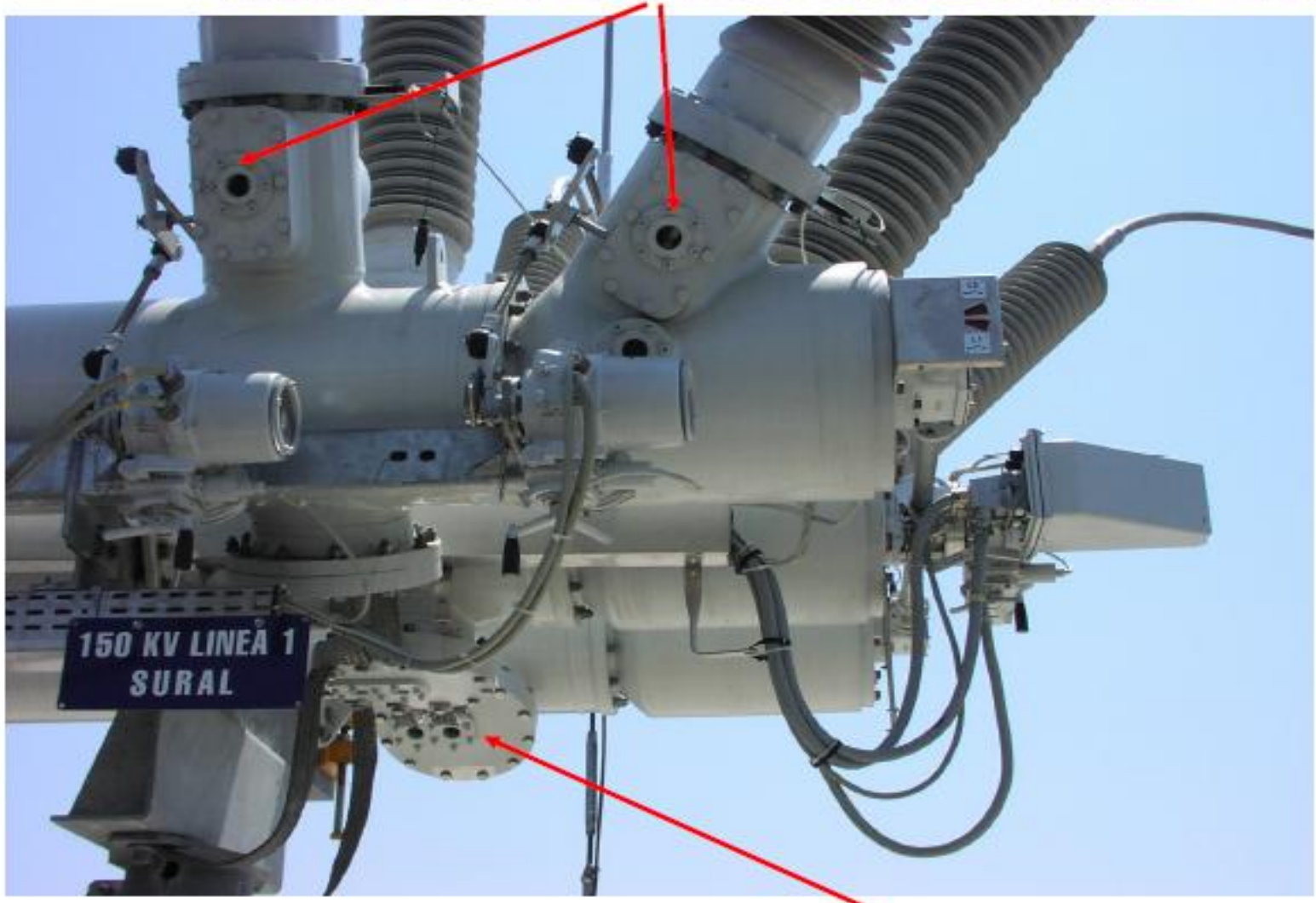

PASS (Plug And Switch Systems)

PASS M0 SBB (BARRA SENCILLA)

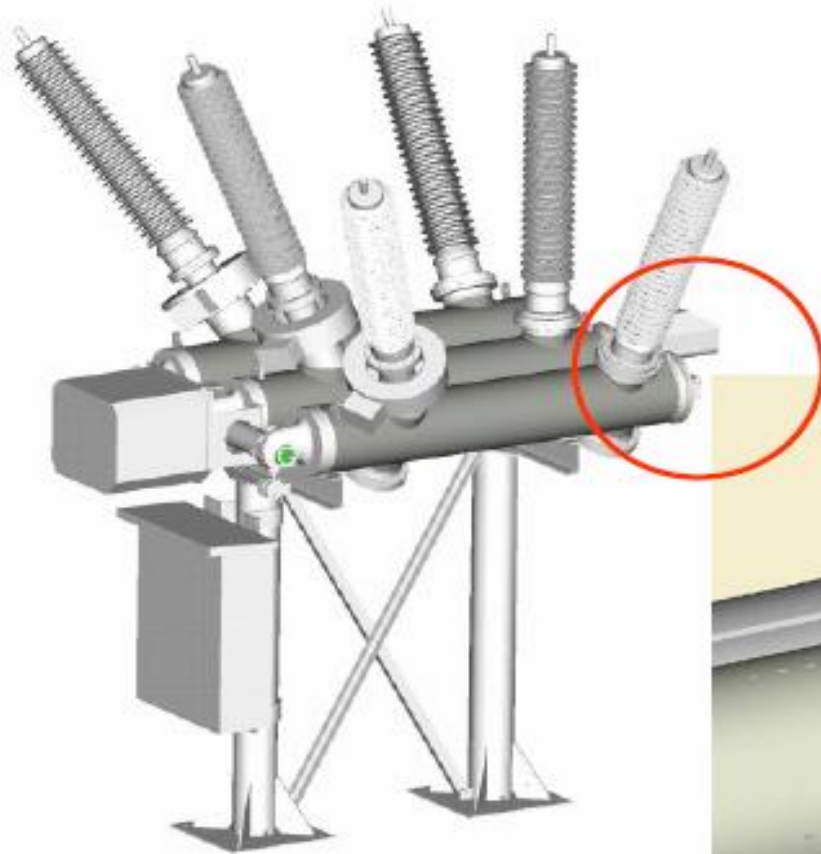

Cuchilla
desconectadora//c.p.t.

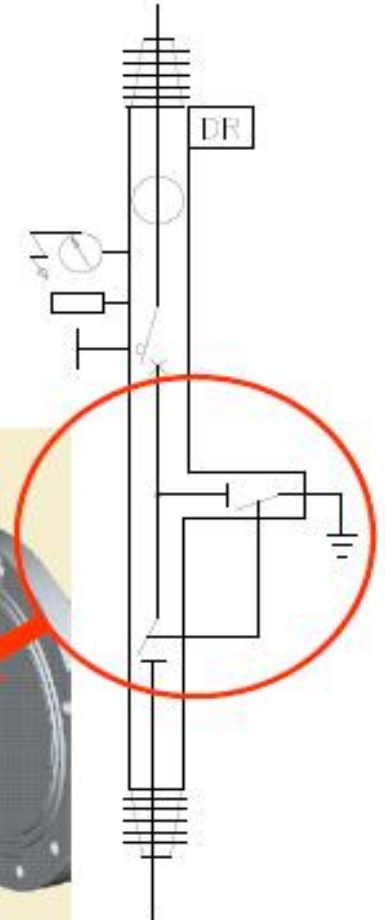
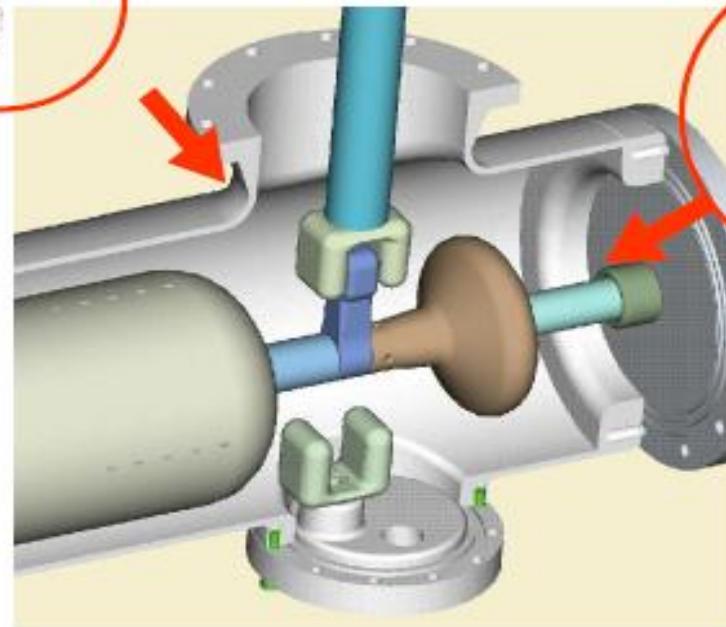

PASS (Plug And Switch Systems)

PASS M0 DBB (DOBLE BARRA)

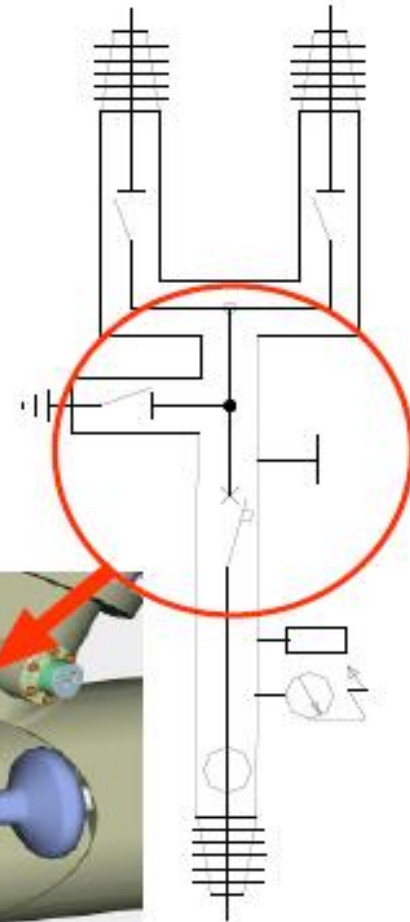
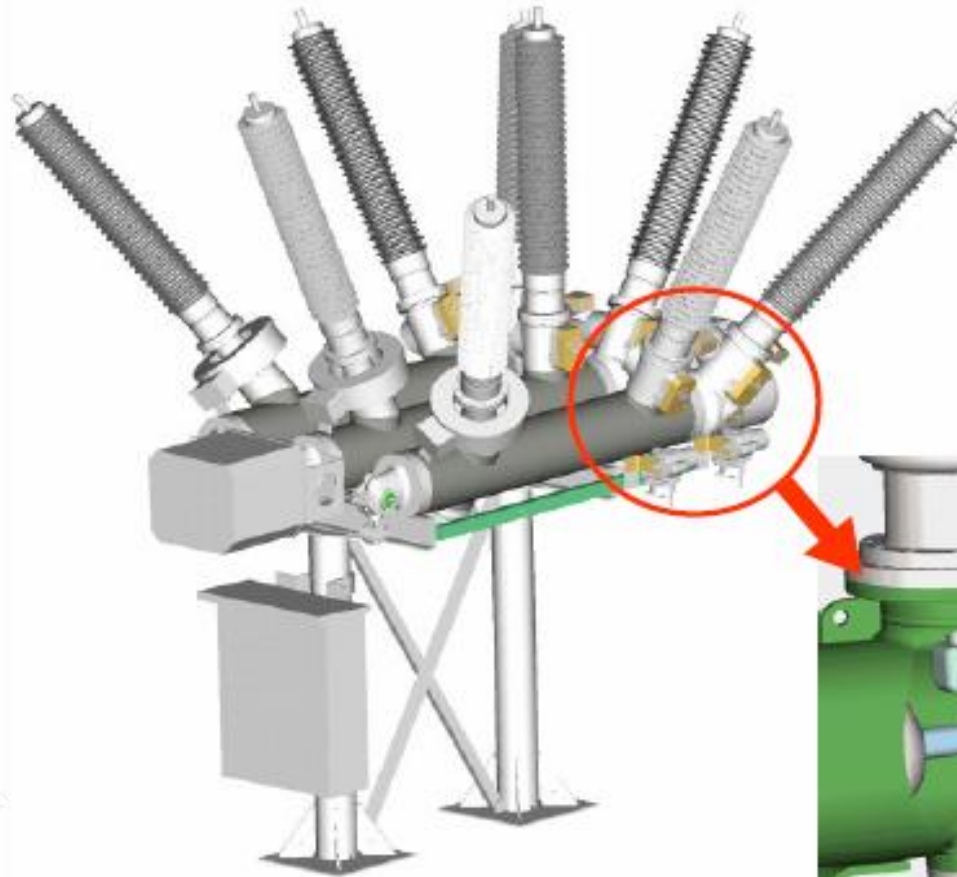

PASS (Plug And Switch Systems)

TRANSFORMADORES DE CORRIENTE

CT EN LAS BOQUILLAS DE CADA FASE, TIPO DONA - IEC 60044-1



CURRENT RATINGS		
Rated continuous current	A	2500
Rated short-time withstand current	kA	40
Rated short circuit duration	s	1
Rated peak withstand current	kA	104
Temperature rise of active parts at rated	°C	≤ 65
Temperature rise of terminals at rated continuous current	°C	≤ 50
Temperature rise of enclosure at rated continuous current	°C	< 15

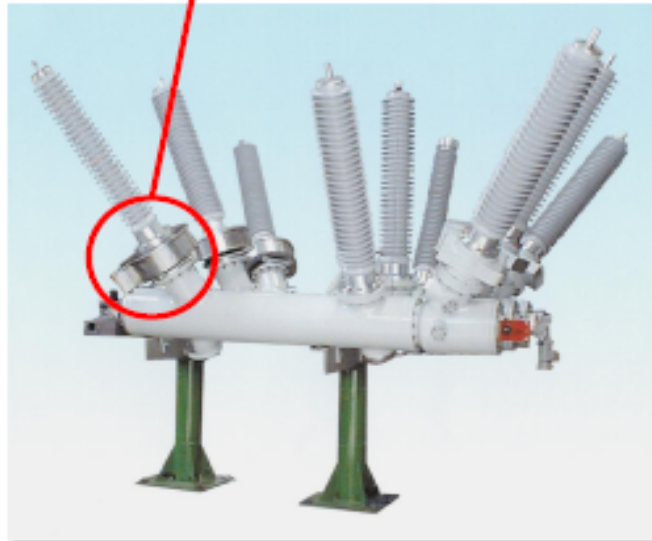

Current Transformer (example)		
Current Ratio	A	600/1-1-1-1-1-1
Cores		6
Accuracy class of measurement cores - 3		3x10VA cl. 0.2, $F_s < 5$
Burden of protection cores - 3		3x30 VA, 5P20
Rated continuous thermal current	A	1.2 I_N

PASS (Plug And Switch Systems) Instalación

Resumen

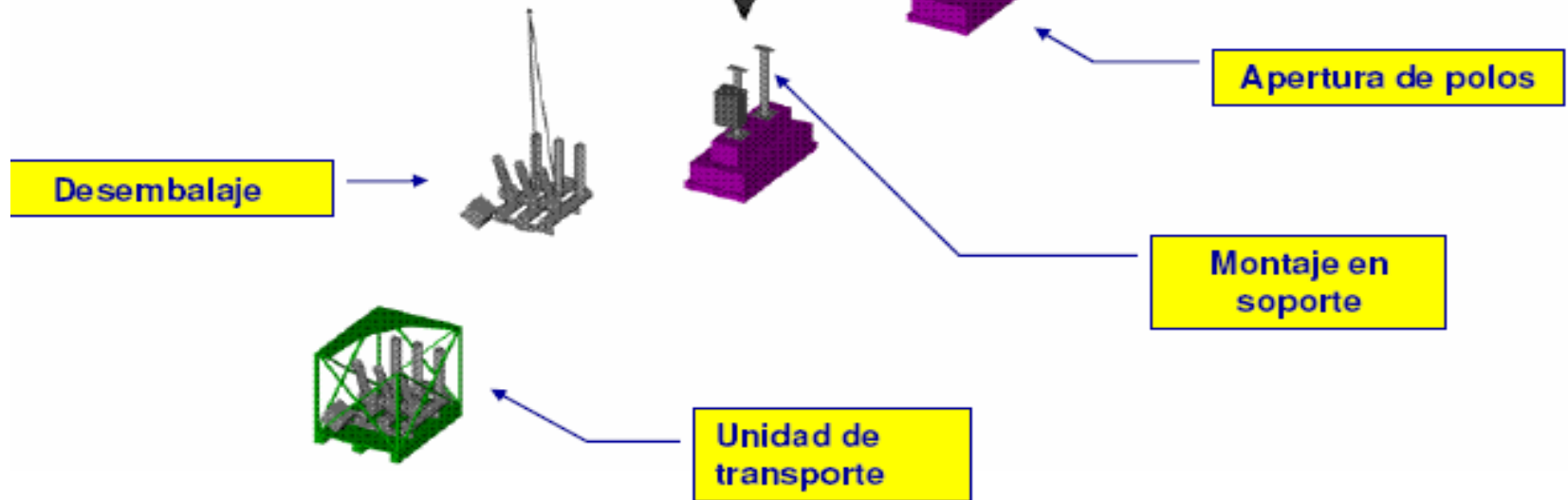

PASS (Plug And Switch Systems) Instalación



1-Foundation prepared for erection



2-Fixing the support by crane



4-Removing the transport structure



3-Unloading PASS M0 module



5-Erection of poles
Fixing by screws



6-Rotation of side poles



7-Service position



8-CB mechanism transmission



9-DS&ES mechanism transmission



10-Filling with SF6 gas at nominal pressure



11-Wiring of CT's to local control panel



12-Functional tests

PASS (Plug And Switch Systems) Operación

disconnector positions			
189 L1	189L2	189TL1	189TL2
CLOSE	CLOSE	OPEN	OPEN
OPEN	OPEN	OPEN	OPEN
CLOSE	OPEN	CLOSE	OPEN
OPEN	CLOSE	OPEN	CLOSE

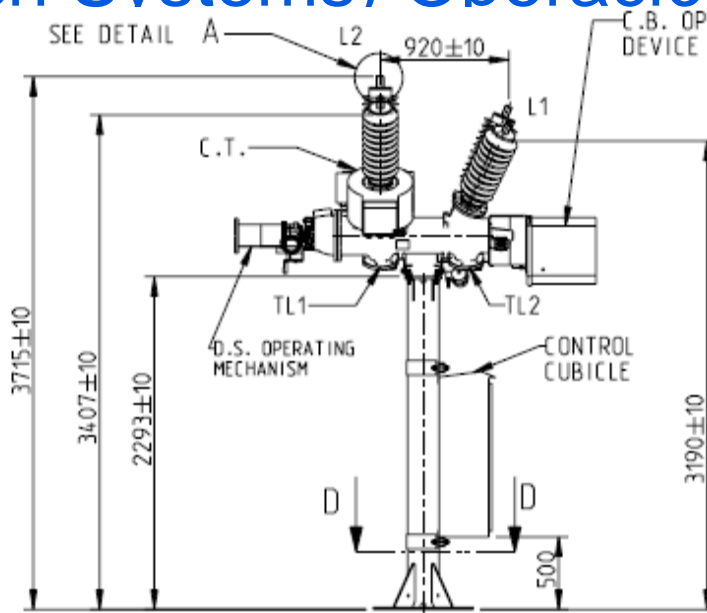
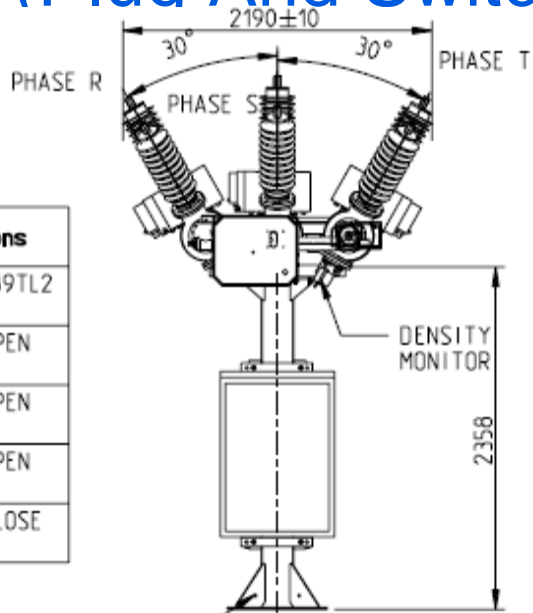

OPERATING DINAMIC LOAD
ORIZZONTAL
8000 N

VERTICAL
1000 N

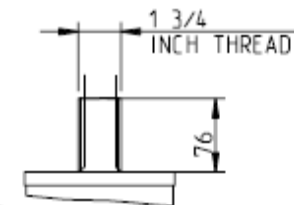

DETAIL A
SCALE 1:5

EARTH CONNECTION Ø16

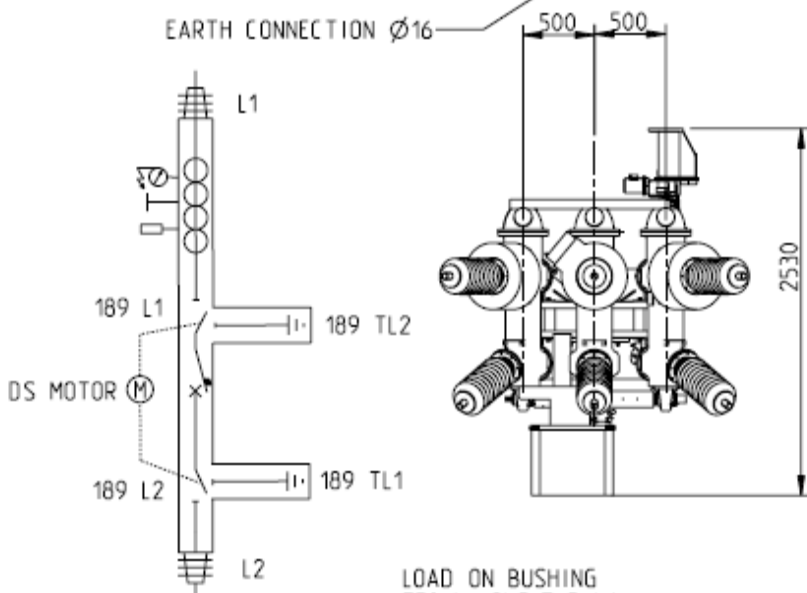

SECTION D-D

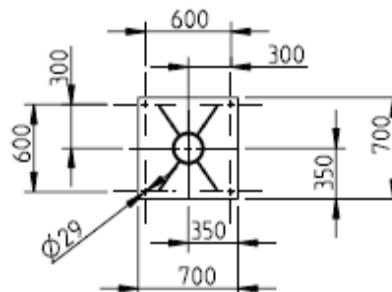

TOTAL MASS 1150 KG
ONLY GAS SF6 8 KG

Modello Pro/E: GVP_PASSM00_SBB_ITA		DISEGNO CAD E' VIETATA LA MODIFICA MANUALE	
Inesso 19/09/02 V. Gorgioni	Control- lato	Control- norme	Data
Origine:	Sostituisce:	Sostituito da:	Senza lista pezzi separ. <input type="checkbox"/>
Mod. A 55829 GV 16-04-03	Mod.	Mod.	Scala LP separ. stesso N. <input type="checkbox"/>
Mod. B EQ 13/05/03 GV	Mod.	Mod.	LP separ. altro N. <input type="checkbox"/>
Mod. C EQ 04/05/04 GV	Mod.	Mod.	COMPUTER DRAWN
Titolo PASS M00 72.5KV			Centro assum.
			Centro resp.

PASS (Plug And Switch Systems) Operación

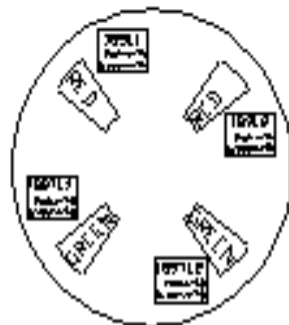
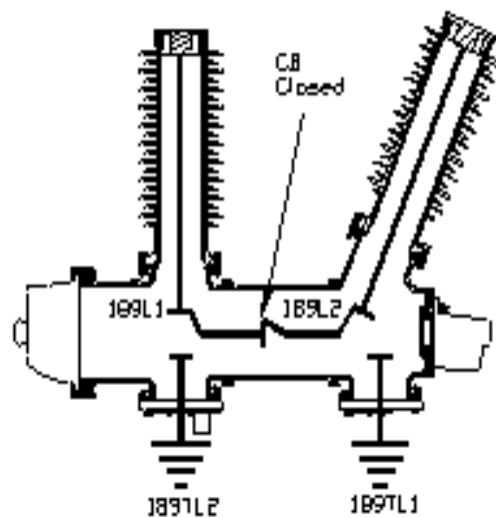

189L1	189L2	189TL1	189TL2
Closed	Closed	Open	Open

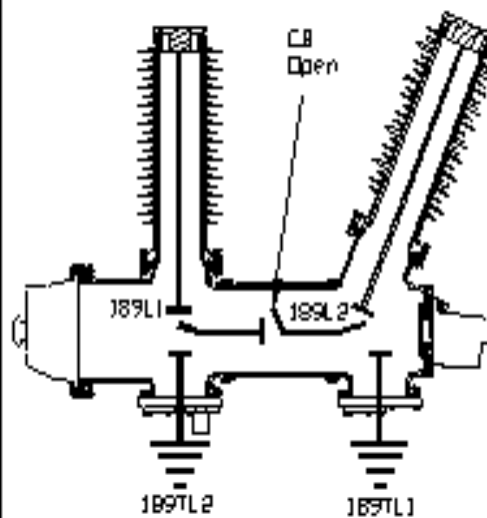

189L1	189L2	189TL1	189TL2
Open	Open	Open	Open

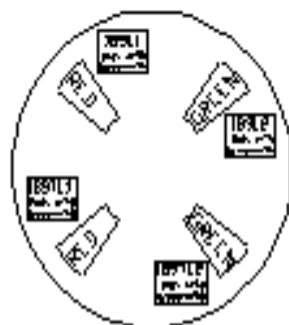
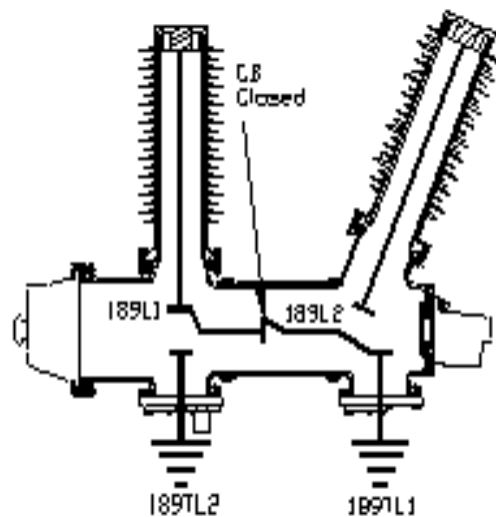

189L1	189L2	189TL1	189TL2
Closed	Open	Closed	Open

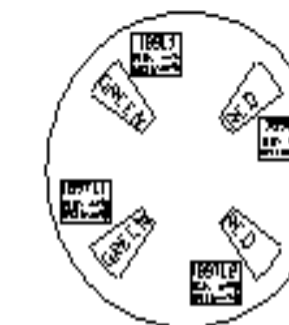
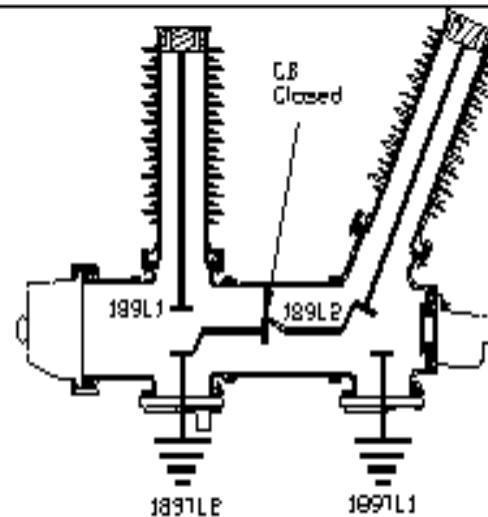

189L1	189L2	189TL1	189TL2
Open	Closed	Open	Closed

PASS (Plug And Switch Systems)

- Cuenta con todas las funciones de una bahia.
- Configuraciones flexibles: Simple barra, doble barra, opcionalmente con conexiones de cable seco.
- Funciones específicas (Interruptor, Seccionador, seccionador de puesta a tierra).
- Fácil instalación e intercambiabilidad.
- Requiere un espacio mínimo para su instalación.
- Alta confiabilidad y menor probabilidad de cortes no programados.
- Simplifica el trabajo en campo y reduce el tiempo de instalación.
- Modular, por lo que permite en caso de ampliaciones y rediseños ahorrar costos y tiempo.



Ejemplo de Aplicación

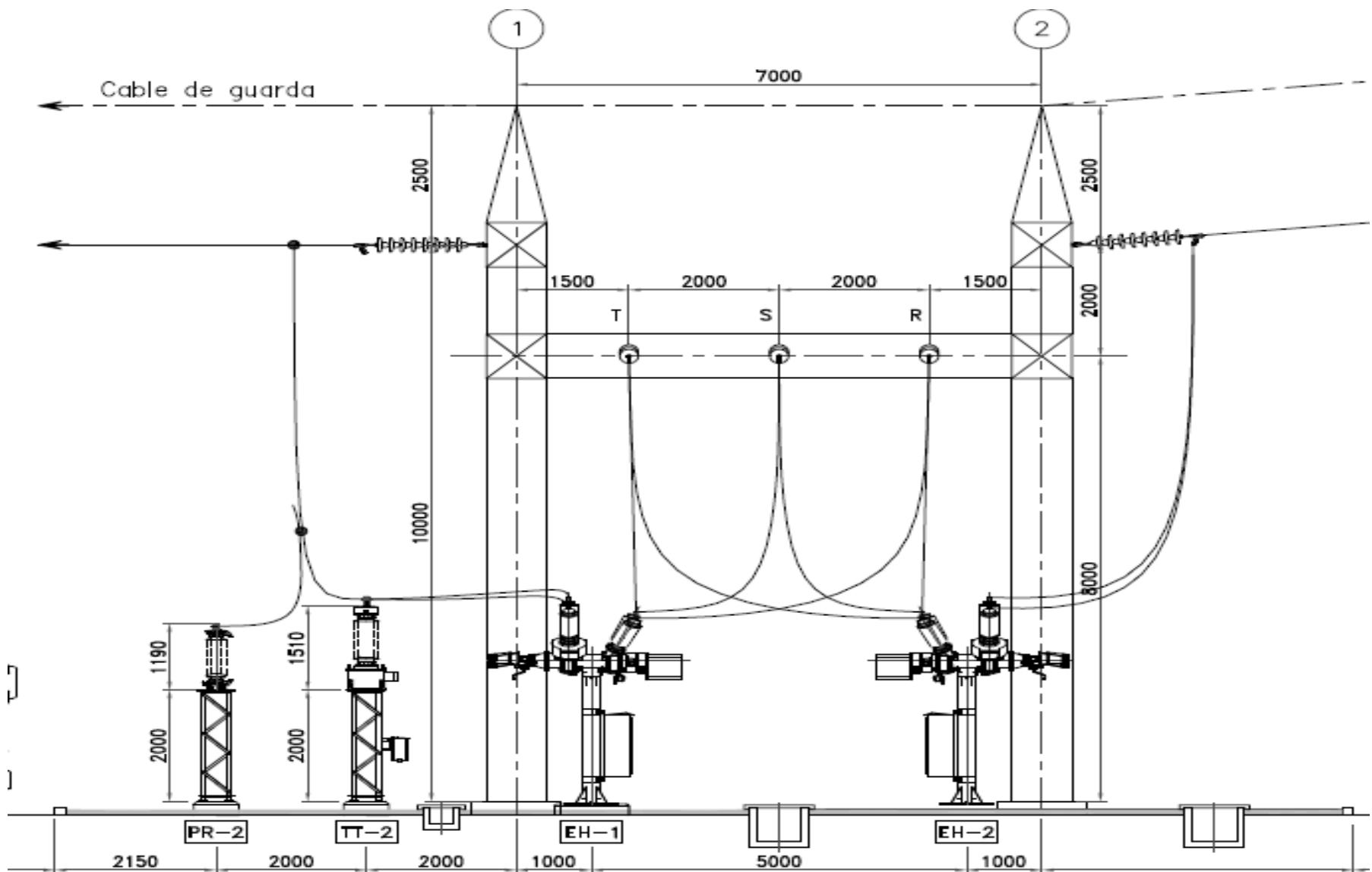

Longitud= 13.15metros

Ejemplo de Aplicación

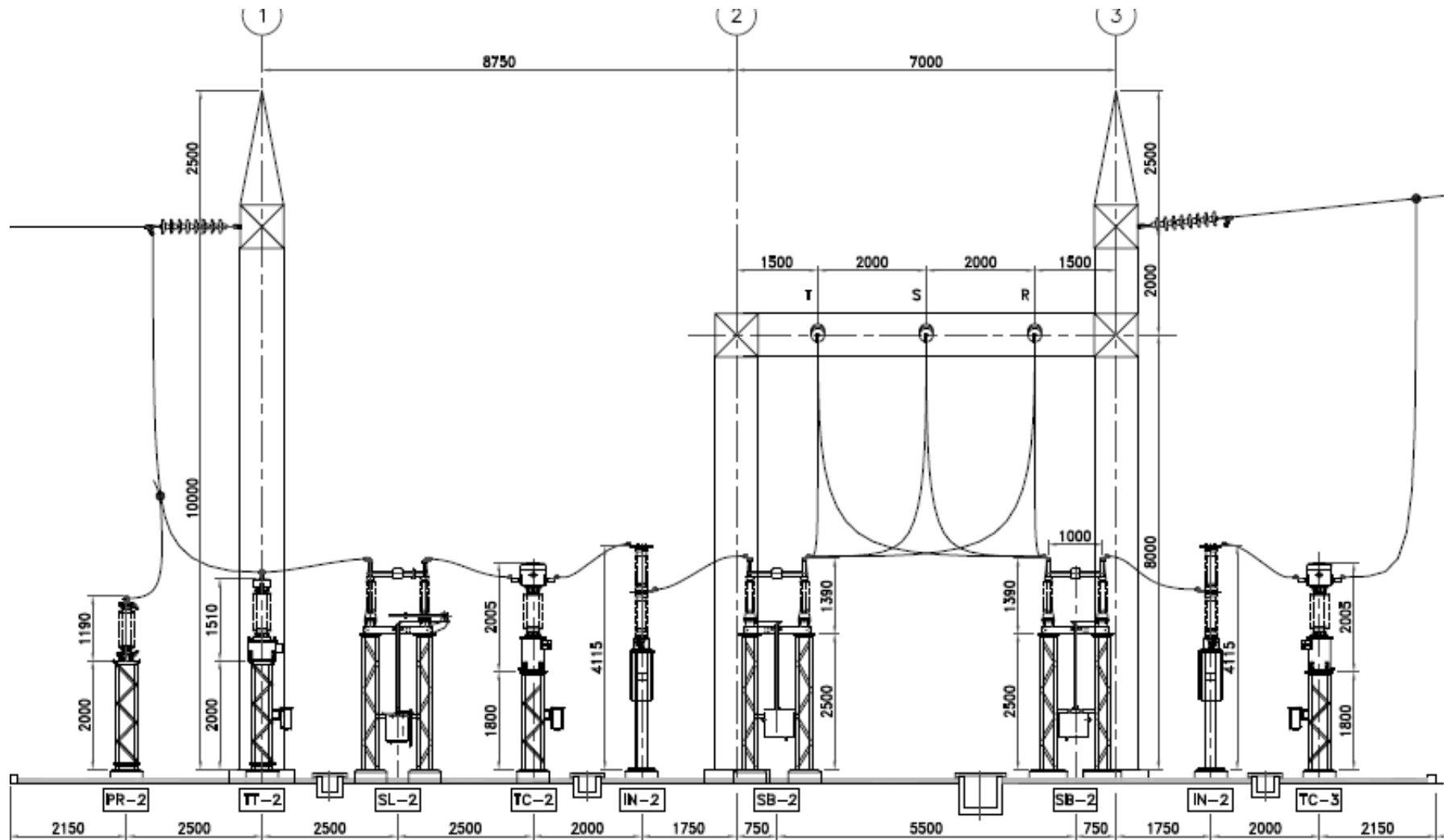

Longitud: 26.3 metros

Evaluación Técnica-Económica

- Ahorro del 50% del espacio previsto para un AIS
- Ahorro en el espacio de la malla de puesta a tierra.
- Ahorro en porticos y las estructuras soporte.
- Ahorro en las obras civiles asociadas(fundaciones).
- Ahorro en el sistema de barras, sistema de apantallamiento.
- Ahorro en el ensamblaje de los equipos.
- Ahorro en el cableado del sistema de control desde el patio de llaves a la sala
- Ahorro en el trabajo de ingeniería.



Evaluación Técnica-Económica

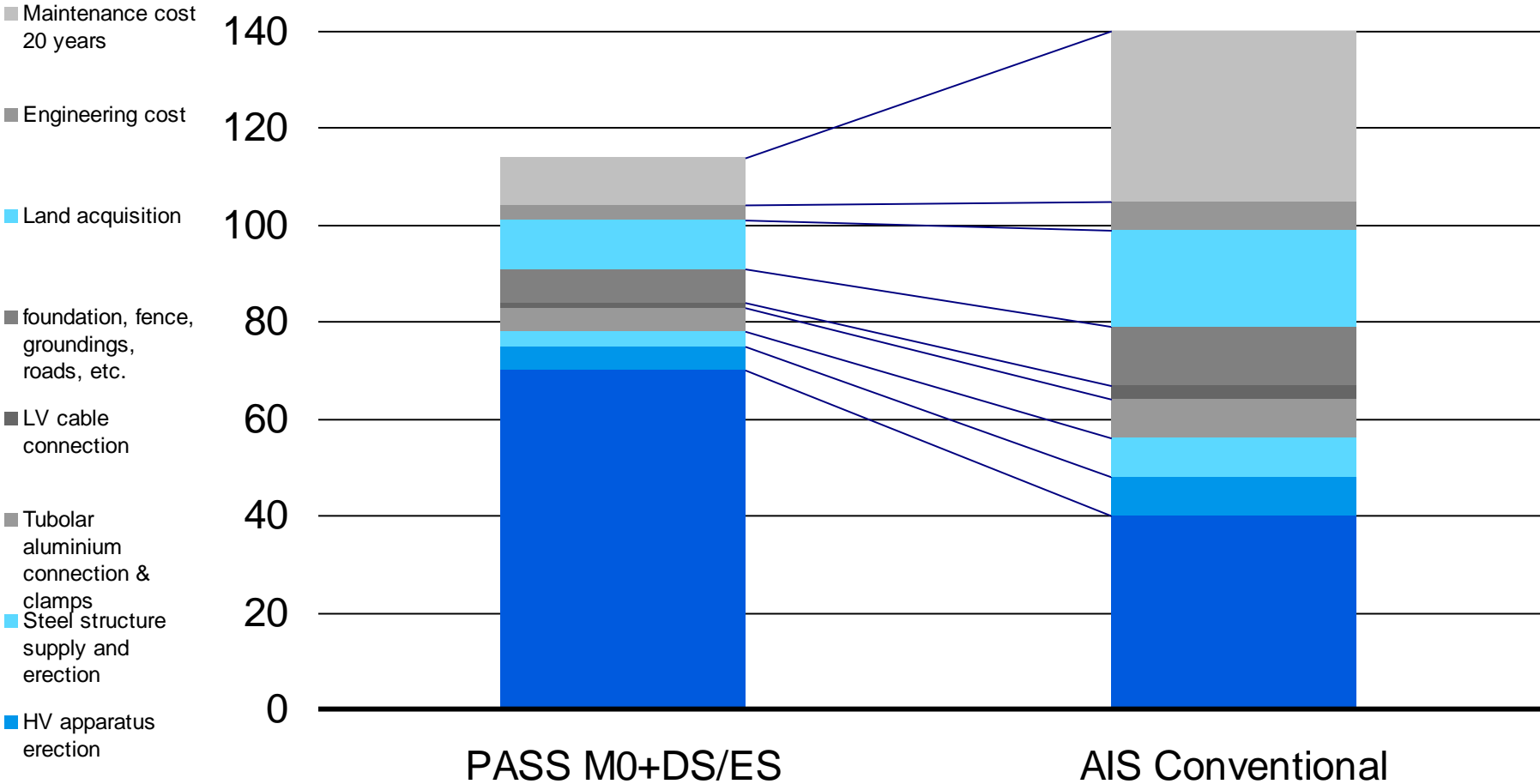

Crterios Adicionales

- Cada caso debe ser analizado para encontrar la mejor solución.
- Para el caso de retrofit el costo de terreno es cero.
- La Ingeniería asociada con el equipo debe ser realizada por un especialista para aprovechar su optimo desempeño.
- Minimo Plazo de entrega del PASS.



Substations Engineering Advisory and Consultancy for Customers

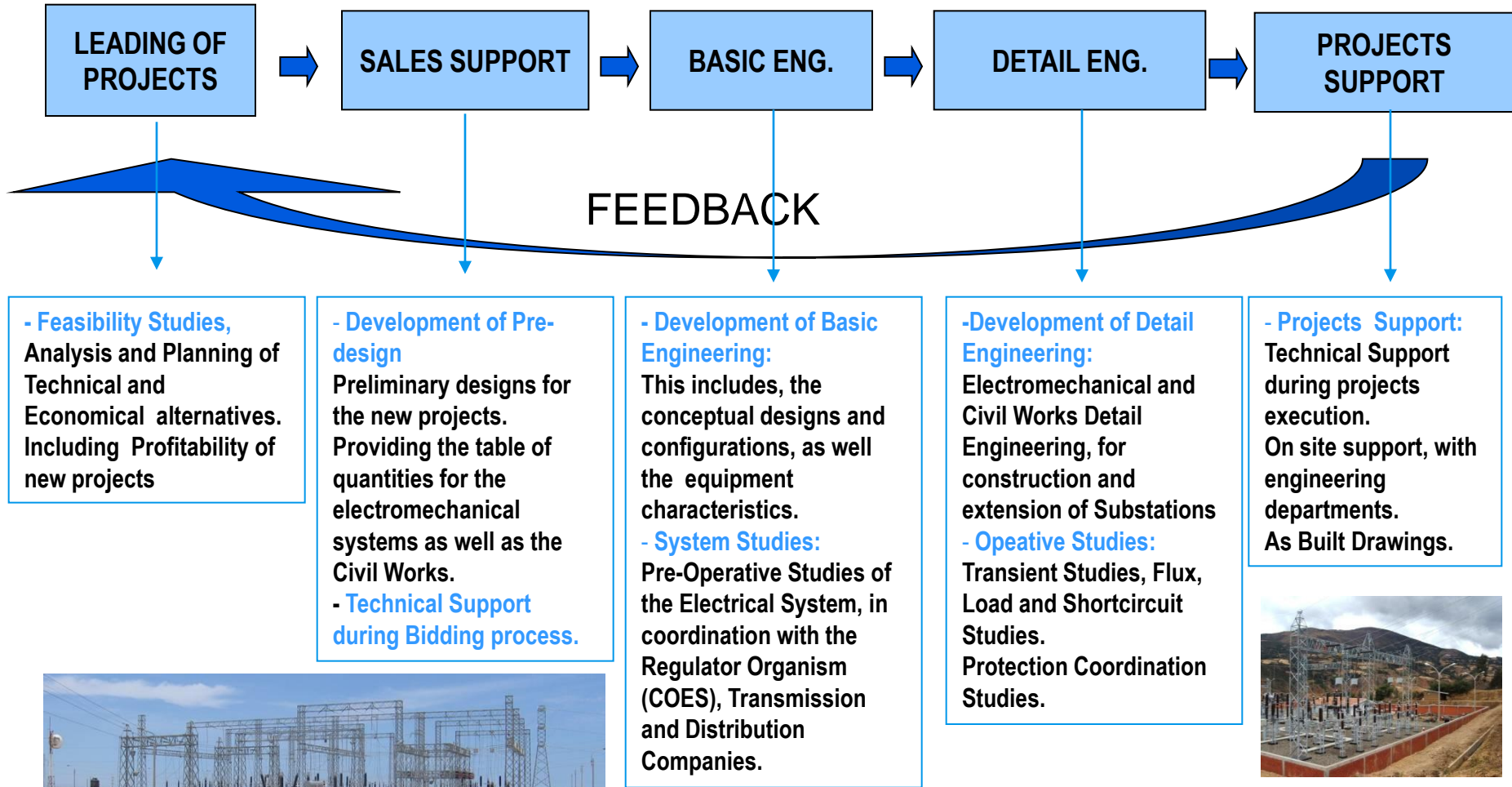

Experience

Condorcocha Substation



- Customer: Cemento Andino S.A.
- Project: “Engineering, erection and commissioning of extension Condorcocha substation”.
- Location: Condorcocha district, Tarma province, Junín department.
- Scope: 02 Bays in 138 kV & 03 Bays in 72.5 kV

Experience

Morena Substation



- Customer: Cia Minera Poderosa S.A.
- Project: “Engineering, erection and commissioning of Morena substation”.
- Location: Vijus district, Pataz province, La Libertad department.
- Scope: 01 bay in 60 kV.

Experience

Cajabamba Substation



- Customer: Cia Minera Poderosa S.A.
- Project: “Engineering, erection and commissioning of Cajabamba substation”.
- Location: Santa Mónica district, Cajabamba province, Cajamarca department.
- Scope: 02 bays in 60 kV.

Experience SdeF Substation



- Customer: Sudamericana de Fibras S.A.
- Project: “Engineering, erection and commissioning of SdeF substation generation plant”.
- Location: Callao province, Lima department.
- Scope: 02 bays in 60 kV.

Experience

Molycop & Puente Substations



- Customer: MOLYCOP - ADESUR S.A.
- Project: “Engineering, erection and commissioning of Molycop and Puente substations”.
- Location: Lima department.
- Scope: 03 bays in 60 kV.

Experience

Substations Pluspetrol - Andoas



- Customer: Pluspetrol Norte S.A.
- Project: “Substations Dorissa, Jibaro, Huayuri, Guayabal, T Dorissa en 66kV”.
- Location: Andoas.
- Scope: 01bay in 60 kV. For substation

Certification Erection & Commissioning

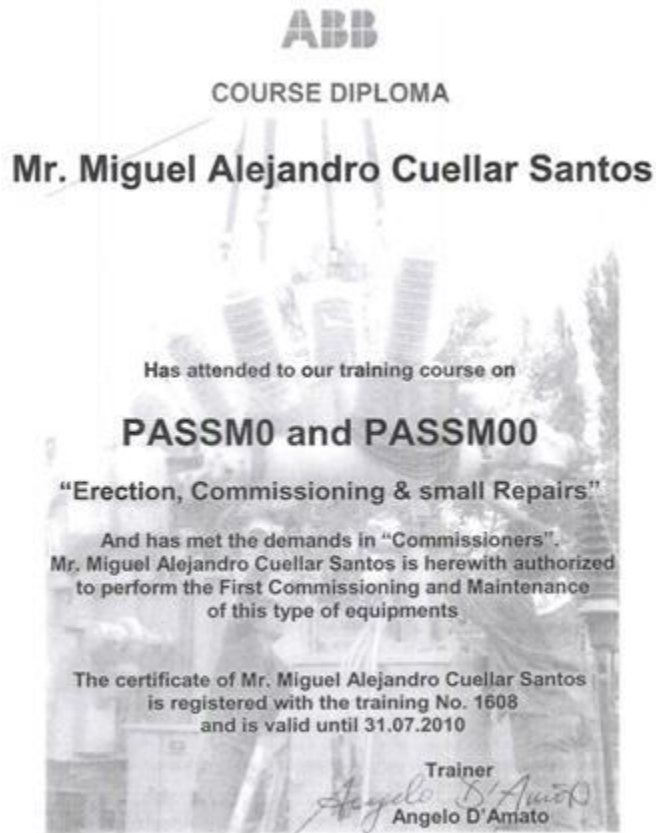

Lodi 18.07.2008
ABB PT u.o. ADDA

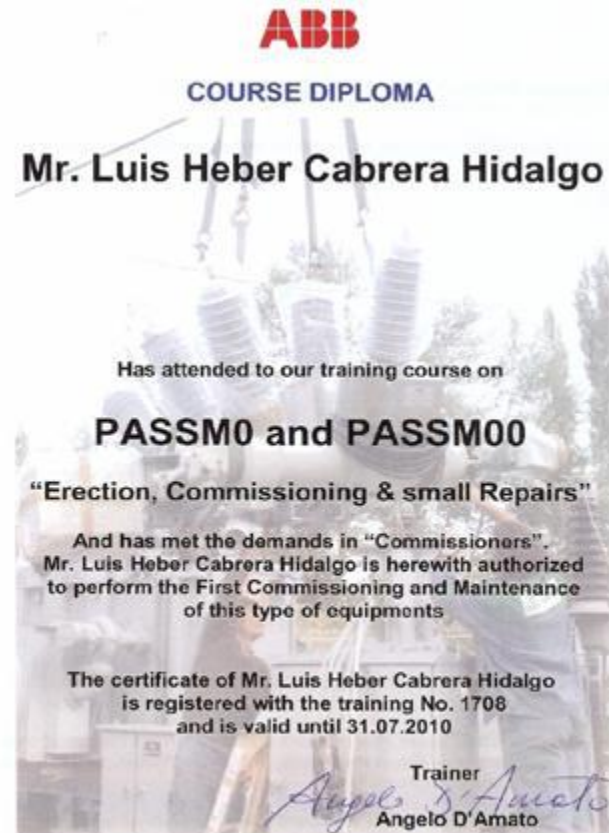

Lodi 18.07.2008
ABB PT u.o. ADDA

Certification ISO 9001:2008



SGS

Certificate PE09/00073

The management system of

ABB S.A.

Av. Argentina 3120
Lima - Perú

has been assessed and certified as meeting the requirements of

ISO 9001:2008

For the following activities



POWER SYSTEMS

Comercialización de sistemas, proyectos y servicios en mercados de generación, transmisión y distribución de energía.

Diseño, fabricación y comercialización de tableros de control, protección y telecomunicaciones aplicados a sistemas de potencia.

Diseño, desarrollo, gestión y ejecución de proyectos y soluciones integrales y servicios en plantas de generación, transmisión y distribución de energía.

Diagnóstico y solución de fallas en sistemas de control y sistemas de electrónica de potencia y electricidad.

Servicios diversos de Electrónica de Potencia, comisionamiento y Servicio de Post-venta de aplicaciones en el sector energía.

Ingeniería, montaje, pruebas y puesta en servicio de Subestaciones de Transmisión, incluye servicios para subestaciones de potencia.

Servicios de Sistemas de Control y Protección, Automatización de subestaciones y Sistemas de telecomunicaciones.

Ingeniería y ejecución de proyectos llave en mano de plantas de generación, sistemas FACTS, sistemas Network Management, sistemas SCADA, sistemas de protección y control, y subestaciones de potencia; aplicados al sector energía, minería e industria.



Power and productivity
for a better world™

